

Series 300C: National Telescoping Crane

America's Leading Manufacturer of Truck-Mounted Hydraulic Cranes.

300C

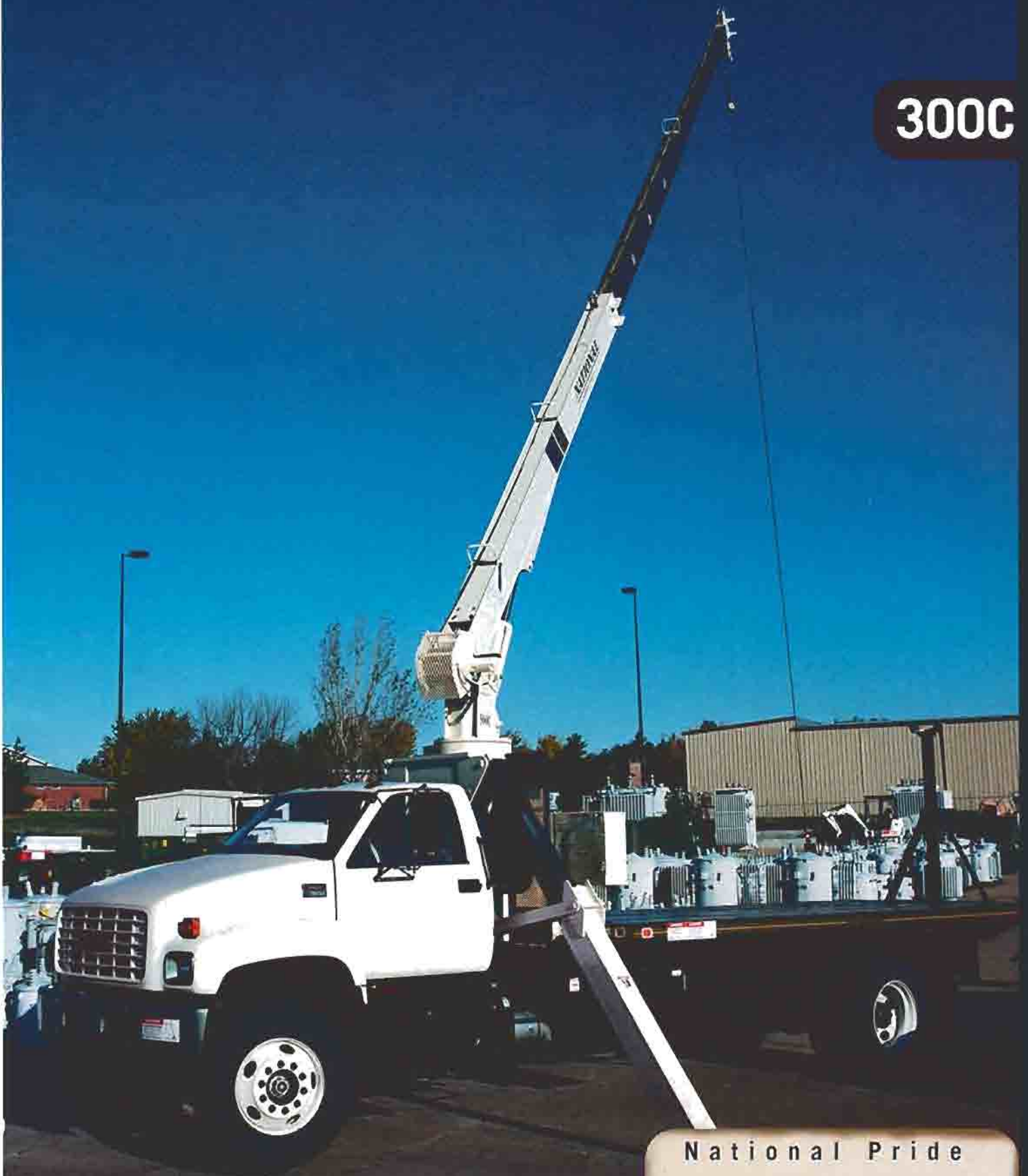

National Pride



NATIONAL CRANE
A Grove Worldwide Company

Why Buy a National Series 300C?



- **8-ton Rating** – The new 300C provides an 8-ton capacity at a five-foot radius.
- **Self-lubricating "Easy glide" Wear Pads** – The self-lubricating pads, standard on the 300C, reduce the conditions that cause boom chatter and vibration. The net result is smoother crane operation.
- **Internal Anti-two-block Wire** – The patent-pending design, standard on the 300C, eliminates the external reel and wire. No more snagging the reel or wire on obstructions.
- **Speedy-Reeve Boom Tip and Sheave Blocks** – These standard features simplify rigging changes.
- **Pre-painted Components** – Painting crane components before assembly reduces the possibility of rust, improves serviceability and enhances the appearance of the machine.
- **Large Oil Reservoir** – Helps reduce heat build-up.
- **Redesigned Frame and Console** – Control valve is now mounted in the console, making it easier to service.
- **Shared Components** – The new 300C has many parts in common with the 400B and 500D, facilitating serviceability.
- **Oil Filter** – The oil filter is now mounted at the tank, not in the crane frame. Filler cap is anti-splash. Reservoir has a stainless steel strainer on fill port.
- **Increased Space Inside Frame** – More room inside the frame makes the unit easier to service.
- **Wiring Harness** – New crane wiring harness simplifies design, improves electrical system reliability, and cleans up inside of console, providing easy access and service.
- **Improved Serviceability and Reliability** –
 - A removable winch allows the internal telescoping cylinder to be removed quickly, without dismantling the boom.
 - Bearings on the boom extend and retract cables can be greased through access holes in the boom side plates.
 - Internal anti-two-block wire routing eliminates damage from external contact.
 - The boom sheave case is open, allowing access to replace the internal anti-two-block wire and to observe internal boom components.
 - Pre-paint reduces rust.
 - Internal boom parts have been reduced, increasing reliability and minimizing downtime when rebuilding the machine.
- **National Crane is the Market Leader** – National is number one in the production of commercial truck-mounted boom trucks. National has many programs and people directly and indirectly involved to provide our customers reliable products.
 - National has the boom truck industry's leading test program. Every structural part of the crane is cycle tested up to 60,000 cycles at full capacity. In addition to cycle testing, each model is subjected to state-of-the-art strain gage testing that measures metal deformation as small as one one-millionth of an inch. The net result is that weak areas are caught in test, not on job sites where costly downtime occurs.
 - Parts are available for all National Crane machines, even if they are 35 years old.
 - National has a formalized quality program and is ISO 9001 approved.
- **National Crane is a Quality Product That Will Provide Years of Service.**

• 8-ton (7,264) maximum capacity

• 62-ft (18.90-m) maximum vertical reach*

• 56-ft (17.07-m) maximum vertical hydraulic reach*

• Hydraulic Capacity Alert system (HCA)

• Proportional boom extension

• High performance planetary winch

* Maximum vertical reach is ground-level to boom tip height at maximum extension and angle with outriggers/stabilizers fully extended.

300C Capacities



Load Rating Chart: Model 346C with no jib

Series 300C Load Rating Charts are available for all Model 328C, 337C and 346C cranes. National will send you a chart by FAX or mail on request - or you may secure needed load rating information through your nearest National Crane dealer.

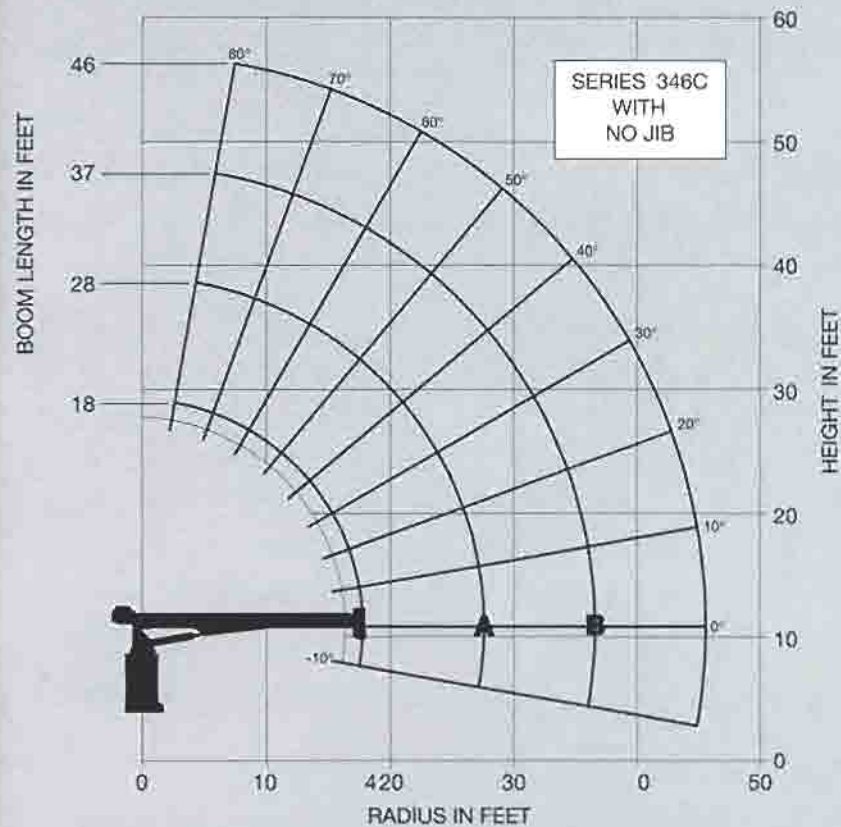

Caution:

- Do not operate crane booms, jib extensions, any accessories or loads within 10 ft (3 m) of live power lines or other conductors of electricity
- Jib and boom capacities shown are maximum for each section
- Do not exceed capacities at reduced radii
- Load ratings shown on the load rating charts are maximum allowable loads with the outriggers properly extended on a firm, level surface and the crane leveled and mounted on a factory-recommended truck
- Always level the crane with the level indicator located on the crane
- The operator must reduce loads to allow for factors such as wind, ground conditions, operating speeds and their effects on freely suspended loads
- Overloading this crane may cause structural collapse or instability
- Weights of any accessories attached to the boom or loadline must be deducted from the load chart capacities
- Do not exceed jib capacities at any reduced boom lengths
- Do not deadhead lineblock against boom tip when extending boom or winching up
- Keep at least three wraps of loadline on drum at all times
- Use only specified cable with this machine
- Maximum capacity with Burst-of-Speed winch is 3,000 lb (1361 kg) on single-part line

LOAD RATINGS

Load Radius (Feet)	Loaded Boom Angle	A		B		C		
		18 Ft. Boom (Lb)	Loaded Boom Angle	28 Ft. Boom (Lb)	Loaded Boom Angle	37 Ft. Boom (Lb)	Loaded Boom Angle	46 Ft. Boom (Lb)
5	74°	16,000						
6	71°	10,250	78°	9,150				
8	64°	8,200	74°	7,400	78°	6,900		
10	56°	6,900	70°	6,100	75°	5,500	79	6,150
12	48°	6,000	65°	5,250	72°	4,700	76	4,600
14	41°	5,200	61°	4,500	69°	4,200	73	3,900
16	27°	4,550	56°	4,050	66°	3,700	71	3,450
18			51°	3,700	63°	3,300	69	3,050
20			46°	3,350	59°	3,050	66	2,800
25			29°	2,600	49°	2,500	59	2,200
30					38°	2,200	51	1,850
35					21°	1,550	42	1,600
40							31	1,250
45							14	950
	0	3,150	0	1,750	0	1,100	0	650

* Shaded areas are structurally limited capacities.

Mounting Configurations

The versatility of the Series 300C can be enhanced by the mounting configurations described below. The configurations are based on a 300C with an 85% stability factor. The complete unit must be installed in accordance with factory requirements and a test performed to determine actual stability and counterweight requirements since individual truck chassis vary.

Configuration 1 with Subspacer

Working area	360°
Gross Axle Weight Rating Front	9,000 lb (4082 kg)
Gross Axle Weight Rating Rear	17,500 lb (7938 kg)
Gross Vehicle Weight Rating	26,500 lb (12 020 kg)
Wheelbase	184 in (467 cm) on 328C and 337C; 202 in (513 cm) on 346C
Cab to Axle/trunnion (CA/CT)	120 in (305 cm) on 328C and 337C; 138 in (351 cm) on 346C
Frame Section Modulus (SM) under crane: 110,000 PSI (758 MPa)	10.0 in ³ (164 cm ³)
Frame Section Modulus (SM) over rear stabilizers: 110,000 PSI (758 MPa)	10.0 in ³ (164 cm ³)
Stability Weight, Front	4,800 lb (2177 kg) minimum, 5,600 lb (2540 kg) maximum*
Stability Weight, Rear	4,600 lb (2087 kg) minimum*
Estimated Average Final Weight	18,300 lb (8301 kg)**

In most cases, if the truck is purchased to minimum specifications, this configuration allows 360° stability without counterweight or rear stabilizers. Since the front tires are used as a stabilizing base, lifting over the front is recommended only for occasional use. If loads are to be continually lifted around the front of the vehicle, front stabilizers are recommended to give the unit a firm base. With this configuration, a payload of approximately 6,000 pounds (2722 kg) can be hauled on a minimum truck.

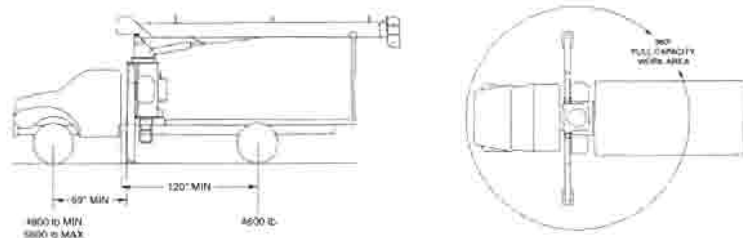

Configuration 2 – Rear Mount with Heavy-duty Subbase

Working area	360°
Gross Axle Weight Rating Front	9,000 lb (4082 kg)
Gross Axle Weight Rating Rear	17,500 lb (7938 kg)
Gross Vehicle Weight Rating	26,500 lb (12 020 kg)
Wheelbase	202 in (513 cm)
Cab to Axle/trunnion (CA/CT)	138 in (351 cm)
Frame Section Modulus (SM) under crane: 110,000 PSI (758 MPa)	10.0 in ³ (164 cm ³)
Frame Section Modulus (SM) over rear stabilizers: 110,000 PSI (758 MPa)	10.0 in ³ (164 cm ³)
Stability Weight, Front	4,800 lb (2177 kg) minimum*
Stability Weight, Rear	5,500 lb (2495 kg) minimum*
Estimated Average Final Weight	24,000 lb (10 886 kg)**

The rear-mounted Series 300C allows the operator to effectively use the close-in working area to lift heavier loads, and provides 360° stability at full rated load. Counterweight may be required on a minimum truck. With this configuration, a payload of approximately 6,000 pounds (2722 kg) can be hauled on a minimum truck. Rear mounts require either "behind the cab" stabilizers (ASHBC) or cross-frame outriggers (HO) and heavy-duty subbase. Underframe stabilizers behind the cab may interfere with the drive line or cause ground clearance problems. If so, contact the factory for alternatives.

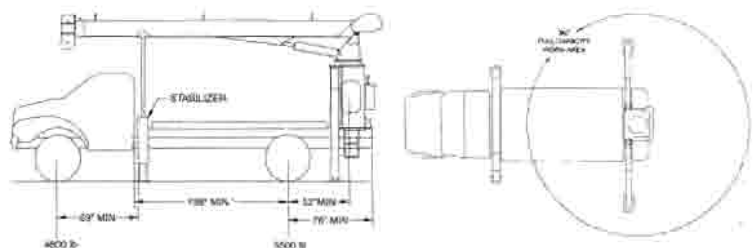

Notes:

- Gross Vehicle Weight Rating (GVWR) is dependent on all components of the vehicle (axles, tires, springs, frame, etc.) meeting manufacturers' recommendations; always specify GVWR when purchasing trucks
- Minimum axle requirements may increase with use of longer wheelbase, service bodies, diesel engines or front stabilizers
- Tandem axle trucks must be used for hauling larger payloads
- Diesel engines require a variable speed governor and energize-to-run fuel solenoid for smooth crane operation; electronic fuel injection requires EET engine electronic throttle

- On trucks shorter than 120 CA, additional weight may be required at the rear axle for 360° stability
- On trucks with front axle weight of 5,200 lbs or greater, a 9,000-lb GAWR (front) will not be adequate if front-mounted stabilizers are used for continuous lifting over the front axle.
- The complete unit must be installed in accordance with factory requirements, and a test performed to determine actual stability and counterweight requirements per SAE J765; contact the factory for details
- Transmission neutral safety interlock switch is required with optional remote control

* Estimated axle scale weights prior to installation of crane, stabilizers and subbase for 85% stability.
 ** Includes all standard crane components, 346C boom, rear bumper, boom rest and bed.

Boom and Jib Combinations Data

Available in three basic models.

Model 328C — Equipped with a 12' 2"-28 ft (3.71-8.53 m) three-section boom.

12' 2"-28 ft (3.71-8.53 m) three-section boom



Model 337C — Equipped with a 15' 2"-37 ft (4.62-11.28 m) three-section boom. This model can be equipped with a 15 ft (4.57 m) single section jib. Maximum tip height with 15 ft (4.57 m) jib is 62 ft (18.90 m).

15' 2"-37 ft (4.62-11.28 m) three-section boom



15' 2"-37 ft (4.62-11.28 m) three-section boom



3FJ15 15 ft (4.57 m) jib

Model 346C — Equipped with an 18' 2"-46 ft (5.54-14.02 m) three-section boom.

18' 2"-46 ft (5.54-14.02 m) three-section boom



Note: Maximum tip height is measured with outriggers/stabilizers fully extended.

300C Winch Data

5

- All winch pulls and speeds in this chart are shown on the third layer.
 - Winch line pulls would increase on the first and second layers.
 - Winch line speed would decrease on the first and second layers.
 - Winch line pulls may be limited by the winch capacity or the ANSI 5 to 1 cable safety factor (3.5 to 1 for optional 6x25 IWRC cable).
 - Hook blocks are rated at maximum capacity for the block.
- Do not exceed rated cable pull with any block.**

Winch	Cable Supplied	Average Breaking Strength	1 Part Line	2 Part Line	3 Part Line
			Lift and Speed	Lift and Speed	Lift and Speed
Standard Planetary Winch	Standard 1/2" Diameter Rotation Resistant	29,200 lb (13,250 kg)	5,840 lb (2650 kg) 184 fpm (56 m/min)	11,680 lb (5300 kg) 92 fpm (28 m/min)	16,000 lb (7257 kg) 61 fpm (19 m/min)
	Optional 1/2" Diameter 6x25 IWRC	26,600 lb (12,066 kg)	5,840 lb (2650 kg) 184 fpm (56 m/min)	11,680 lb (5300 kg) 92 fpm (28 m/min)	16,000 lb (7257 kg) 61 fpm (19 m/min)
Optional High-pull Planetary Winch	Standard 9/16" Diameter Rotation Resistant	38,500 lb (17,463 kg)	7,700 lb (3493 kg) 110 fpm (34 m/min)	15,400 lb (6985 kg) 55 fpm (17 m/min)	16,000 lb (7257 kg) 57 fpm (11 m/min)
	Optional 9/16" Diameter 6x25 IWRC	33,600 lb (15,241 kg)	8,400 lb (3811 kg) 110 fpm (34 m/min)	16,000 lb (7257 kg) 55 fpm (17 m/min)	N/A N/A

Block Type	Rating	Weight
Downhaul Weight	4.20 ton (3.80 t)	90 lb (41 kg)
1 Sheave Block	9 ton (8.16 t)	100 lb (45 kg)

Winch	Bare Drum Pull	Standard Cable Limited	Optional Cable Limited
Standard Planetary	6,900 lb (3130 kg)	5,840 lb (2650 kg)	7,600 lb (3447 kg)
Optional Planetary	10,200 lb (4627 kg)	7,700 lb (3493 kg)	9,600 lb (4354 kg)

Accessories

Radio Remote Controls - Eliminate the handling and maintenance concerns that accompany cabled remotes. Operate to a range of about 250 feet (76 m), varying with conditions.

- **Model R3R** (lift, turn, telescope)
- **Model R4R** (adds winch control)

One-Person Basket - Strong but lightweight steel basket with 300-lb (139-kg) capacity, gravity-hung with swing lock and full body harness.

- **Model B1-S**
- **Model 2B1-S** (for dual locking baskets)

Pallet Fork - Manual leveling fork with adjustable throat and teeth, 4,400-lb (1996-kg) capacity.

- **Model MKF**

Loose Material Clam - Moves up to 2/3 yard³ (.50 m³) material. Bucket hooks easily to loadline and includes manual control hose reel.

- **Model LMC**

Hydraulic Oil Cooler - Automatic, self-contained radiator system with electric fans cools oil under continuous operation.

- **Model OC**

Continuous Rotation - Allows rotation of turret/boom without stop.

- **Model CR**

Burst-of-Speed Winch - Provides faster winch payout and pickup of cable. Increases line speed up to 50 percent over normal.

- **Model BOS**

High-Pull Winch - Increases winch pull to 9,600 lb (4354 kg). (With optional rope.)

- **Model HPW**

SERIES	G CENTER OF GRAVITY FROM CENTERLINE		
	G	DRY WEIGHT*	W/OIL WEIGHT*
348C	36" (914 mm)	7775 lb (3525 kg)	8100 LB (3675 kg)
337C	29" (737 mm)	7450 lb (3375 kg)	7775 LB (3525 kg)
328C	22" (559 mm)	7150 lb (3250 kg)	7475 LB (3400 kg)

*Above weights do not include subbase, rear stabilizers, jibs, PTO, pump, boom rests or options.

SPECIFICATIONS

Dimensional Specifications

	WEIGHT	G	SIZE
Std. Full Length T-Box	1,150 lb (520 kg)	103 in (2,617 mm)	35 in W x 254 in L x 8 in H (889 mm W x 6,452 mm L x 203 mm H)
Rear Mount H.D. T-Box	1,200 lb (544 kg)	87 in (2,210 mm)	35 in W x 214 in L x 8 in H (889 mm W x 5,436 mm L x 203 mm H)
Std. Subbase Spacer	230 lb (104 kg)	0 in (0 mm)	35 in W x 37.5 in L x 8 in H (889 mm W x 953 mm L x 203 mm H)

NOTE:
Dimensions are in inches (mm) unless otherwise specified.

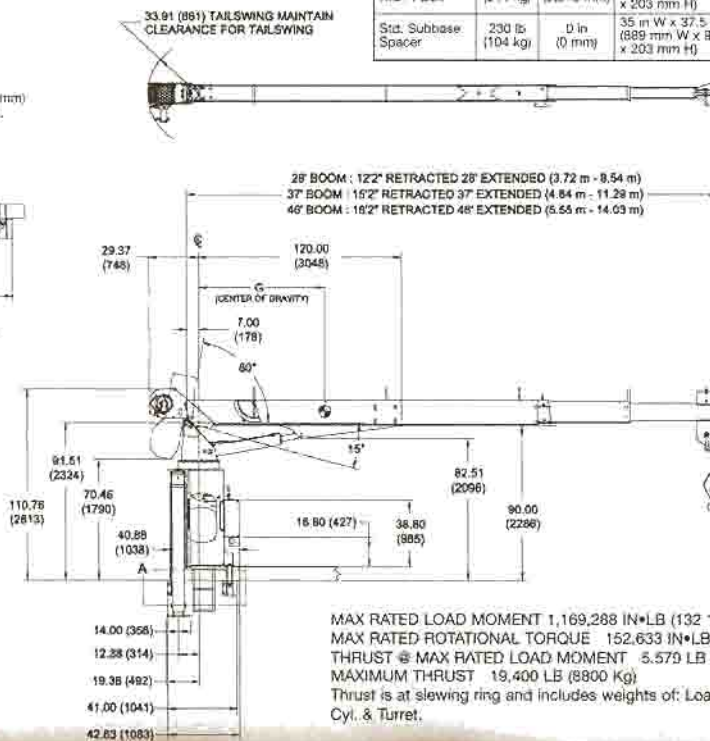
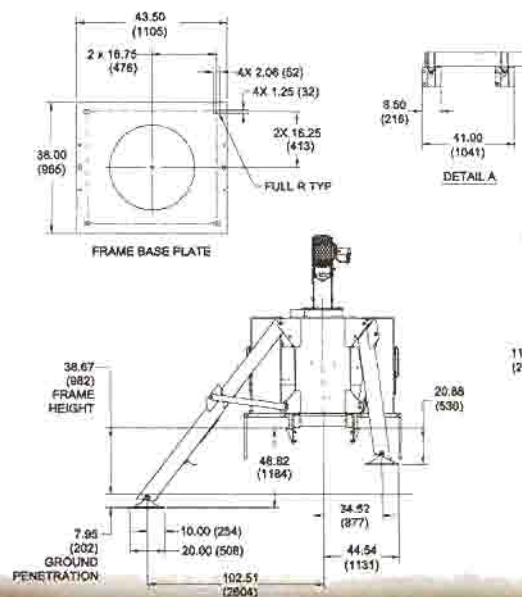

MAX RATED LOAD MOMENT 1,169,288 IN*LB (132 112 Nm)
 MAX RATED ROTATIONAL TORQUE 152,633 IN*LB (17 244 Nm)
 THRUST @ MAX RATED LOAD MOMENT 5,579 LB (2531 Kg)
 MAXIMUM THRUST 19,400 LB (8800 Kg)
 Thrust is at slewing ring and includes weights of: Load, Boom, Lift Cyl. & Turret.



NATIONAL CRANE
 A Grove Worldwide Company

Your National Dealer:

National Crane is
 ISO 9001
 Certified

General Offices:
 11200 North 148th Street
 Waverly, NE 68462 USA
 Phone: (402) 786-6300
 FAX: (402) 786-6363
 Email: sales@nationalcrane.com
 Web: www.nationalcrane.com

National Crane reserves the right to change designs, prices and specifications at any time without notice.
 Printed in U.S.A. Form No. 300C/0502/5M/AA/JN